



2015 FASTRAK DIRT LATE MODEL RULE BOOK

(ALL RULES ARE SUBJECT TO CHANGE OR AMENDED BY FASTRAK OFFICIALS)

All changes from previous year will be in RED

RULE BOOK DISCLAIMER

The rules and/or regulations set forth herein are designed to provide for the orderly conduct of racing events and to establish minimum acceptable requirements for such events. These rules shall govern the condition of all events, and by participating in these events, all participants are deemed to have complied with these rules. **NO EXPRESSED OR IMPLIED WARRANTY OF SAFETY SHALL RESULT FROM PUBLICATION(S) OF OR COMPLIANCE WITH THESE RULES AND/OR REGULATIONS.** They are intended as a guide for the conduct of the sport and are in no way a guarantee against injury or death to a participant, spectator, or official.

The race director shall be empowered to permit reasonable deviation from any of the specifications herein or impose any further restrictions that in his/her opinion do not alter the acceptable minimum acceptable requirements and/or in the fairness of competition. **NO EXPRESS OR IMPLIED WARRANTY OF SAFETY SHALL RESULT FROM SUCH ALTERATION OF SPECIFICATIONS.** Any interpretation of deviation of these rules is left to the discretion of the officials, Their decision is final.

All participants, fans, car owners, officials agree to a "hold harmless" contract by competing in or being present at a FASTRAK weekly or touring event. Should litigation of any decision or incident be required all parties as stated about agree that litigation will take place in the County of Franklin, State of Georgia.

YOU MUST HAVE MEMBERSHIP CARDS FOR PROOF AT EVERY EVENT WEEKLY OR TOUR

SECTION 1 NAMES, COMPANY INFORMATION

FASTRAK Companies International LLC
DBA/FASTRAK Racing Series
Mail: PO Box 590, Carnesville GA 30521
Overnight: 8077 Royston Road, Carnesville GA 30521

Office: (678) 935-7304	Fax: (678) 528-3117	website: www.fastrakracing.com	
Director Daily Operations	Jody Palmer	(678) 935-7304 Extension 2#	cell: (864) 710-1544
Finance/souvenirs	Mary K Combes	(678) 935-7304 Extension #1	
Engine Seals/Office manager	Jessica Cornett	(678) 935-7304 Extension 4#	
National Tech Director	Brad Hibbard		cell: (330) 540-7223
SE Race Director	Jody Palmer	(678) 935-7304 Extension 2#	cell: (864) 710-1544
NE Race Director	Joel Prosser	(678) 935-7304 Extension 2#	cell: (706) 340-4781
Cross Roads Director	Phillip Worrick		cell: (765) 618-5158
SE Public Relations	Wesley Outland		cell: (919) 262-5660
NE Public Relations	Marcie Barlow		cell: (724) 816-8482
ULTIMATE Supers LM	Kelley Carlton		cell: (864) 871-1442
Owner:	Stan Lester	(678) 935-7304 Extension 5#	

Engine Rebuilders: Go to www.fastrakracing.com and look under “engines” tab

Facebook: FASTRAK Racing Series

SECTION 2 COMMUNICATION – UPDATES -ETC

TECHNICAL UPDATES Please make sure we have your email address for updates. We DO NOT mail updates or rule changes.

TEXT COMMUNICATION We now have the ability to communicate with you via text. Get us your info ASAP. This is the fastest way we know to get in touch w you. Great help in case of rain outs etc.

TRACK REPS Polls will be sent to the weekly tracks and regional tours. Each weekly sanctioned track and each tour should have two (2) representatives. These people are there to have your voice in mind. As things grow, It’s more difficult to stay in touch. They will report via video conference with us once a month to let us know what’s going on around you. Is your track not teching, do you not like a rule, anything it might be these people are there to represent you. Make sure these are level headed people you want to represent you, not the most popular person, and that they can and have the ability to know how to use a video conference system. We think this is our most important improvement this season is being able to communicate with you, our teams. Ask your track about the poll before the first race. It will be there. THIS IS VITAL to the continued growth of this type of racing.

SECTION 3 MEMBERSHIP(S) FEES As of this season everything changed in the way of memberships.

\$125 ONE FEE ONLY! No more tour and weekly fee of \$100 each. Only (1) \$125 fee for everything!

You must be a member to run for any point monies awarded by FASTRAK.

You must be on FT 200/400/00 to receive points or to qualify for World Championship event

SECTION 4 EVENT TYPES- CHAMPIONSHIP(S)

WEEKLY SANCTIONED TRACK: A track that operates under FASTRAK weekly sanctioning rules and is under contract with FASTRAK. IN 2015 \$10,000 to win paying through top 50 teams (explanation under pay outs)

TOURING EVENT: The larger paying traveling shows. A tour will travel the region. Most of the shows will pay more than the weekly tracks because of the travel. Touring events with FASTRAK pay a minimum of \$1200 to win and have been as much as \$50,000 to win for the Grand Nationals.

NATIONAL WEEKLY CHAMPIONSHIP Our most successful year with a weekly championship has been doing it this way. \$10,000 to win and pays through the top 50 from the FASTRAK weekly sanctioned tracks. Great Championship and gives the weekly teams a real chance to win the \$10,000 prize.

TOURING CHAMPIONSHIPS The FASTRAK tours are currently in the Southeast based out of GA. Northeast based out of WV and Crossroads based out of Indiana. (Section 1) Total of points from all touring events in that region plus bonus races. The number of drops is based on the number of events in that region.

NATIONAL EVENTS No more national events.

BONUS EVENTS Events \$3000 and up that will be added to ALL POINTS.

POINT SYSTEM: 35,34,33,32,31,30,29,28,27,26,25,24,23,22,21,20,19,18,17,16,15,14,13,12. Any position after 24th will receive 11 points. MUST TAKE THE GREEN FLAG UNDER "COMPETITION" to receive any points. This includes having legitimate mechanical issues. No team may "Start and Park" solely for the reason to qualify for the season ending championship. Check with series tech person to insure legitimacy.

NATIONAL WEEKLY CHAMPIONSHIP: Best 15 races. Since there is only one membership now, points from touring events count towards National Weekly Points as well. Races do not count until membership is in.

TOURING CHAMPIONSHIPS: Total of all points from that season. Races do not count until membership is in.
Drops: 10- races (1) drop 16 and up (2 drops)

WORLD CHAMPIONSHIP: Must have 10 races and be a member of FASTRAK. Races do not count until membership is in.

Thursday: Open Practice Friday: (2) \$3000 to win features (must meet all criteria plus you cannot have won a super late model event in the same season).

Saturday: \$15,000 to win \$500 to start (open to all members with 10 races in)

10 races: means 10 races at either a FASTRAK weekly sanctioned track (check website) and/or touring event. Any time you have tires on other than FT200/400/600 those events do not count towards ANY FASTRAK awards or races.

WORLD CHAMPIONSHIP : Events to qualify (10). FASTRAK reserves the right to “adjust” number of races based on inclement weather etc and/or anything “beyond our control”.

RULE ADJUSTMENTS All rules are at the discretion of SERIES Officials. FASTRAK reserves the right to amend or adjust, change, delete the rules without notice.

SPIRIT OF COMPETITION These rules are designed for crate engine racing. Crate engine racing is designed whereby everyone has the same engine thereby giving no one a distinct “advantage”. The “spirit of competition” applies to the rules and regulations of any and all FASTRAK events.

PAYMENT OF PURSE FASTRAK is not responsible for the purse. Should a track not pay as “agreed upon” FASTRAK will work on behalf of teams for payment.

PROTEST AND FEES Top 5 cars in ANY event can protest ANYONE in the top 5 positions.
Complete tear down: \$1000 (\$200 goes to inspector) Cam Profile: \$300 (\$100 goes to inspector)
Head and Intake: \$300 (\$100 goes to inspector)
NOTE: Protest fee for an engine sealed with anything other than FASTRAK seals or NEW GM Bolts are 50% of any posted amount(s)
2 day show or back to back events, engine(s) may be marked for legality and teched afterwards.
In the event a competitor has more than one engine, before replacing primary engine a FASTRAK Official must be notified and engine must be marked. Both engines must be present to be inspected. No advance notification of an engine change will result in immediate disqualification. On non FASTRAK sealed or new GM bolts engines FASTRAK “authorized” engine rebuilder is not responsible to put engine back together for the \$600 contracted amount.

ENGINE SEALS At the start of the 2016 season NDRA seals are not legal. RM bolts are not legal. No personal engine builder seals will be legal.

FASTRAK is considering no longer requiring engine seals at all thereby letting you rebuild your own engines. We would like your input.

FASTRAK RESERVES THE RIGHT TO CHECK A COMPETITORS ENGINE BY ANY MEANS AT THE DISPOSAL OF THE TECH INSPECTOR OR FASTRAK ENGINE REBUILDER. FASTRAK WILL CHOOSE THE PERSON INSPECTING THE ENGINE. Any competitor that will not allow the engine or part(s) to be inspected will be automatically disqualified and considered “cheating within the bolts” thereby all penalties applying thereof. Competitor will be barred 365 and fined \$1000 for “cheating within the bolts” and car owner if different from driver will have same fine(s) imposed. ALL ILLEGAL PARTS WILL BE CONFISCATED AND DESTROYED. NOT ALLOWING CONFISCATION OF ILLEGAL PARTS IS CONSIDERED “CHEATING WITHIN THE BOLTS” and penalties thereof apply. Competitor, owner (if different) and car will not be allowed to compete again for 365 days at any FASTRAK event and weekly track(s) and until ALL FINES have been paid.

“CHEATING WITHIN THE BOLTS”

This includes but is not limited to Valve Springs

Driver is fined \$1000 and barred for 365 days

Loss of points

Cannot compete at any FASTRAK track or event until all fines/yime have been paid or satisfied

If car owner is ‘separate’ of driver, car owner will be under the same penalty(s)

Track event: (Track receives 25% of \$1000 fine)

Regional Touring event: (Track receives 25% of fine)

EXCEPTION: If FASTRAK “authorized” engine builder signs legal “affidavit” stating that competitor had NO knowledge of rules infraction in relation to building of ‘said’ engine. *Must be signed in front of Probate Judge in Carnesville GA, County of Franklin.*

Competitor and/or car owner (if separate) will be fined \$500.

Competitor and/or car owner (if separate) will be suspended for 365 days

*ALL RULES in effect for ALL OPEN SHOWS that are FASTRAK Sanctioned.

*By participating in ANY FASTRAK event (Touring, Weekly or Open) Competitor, Owner and any affiliates of such agree to a “hold harmless” agreement under the terms of this rule book.

Competitors, Car Owners, Engine Builders have the right to “appeal” at the FASTRAK Corporate Office. Findings at said appeal shall be binding and FINAL! Appeals must be filed in writing within 48 hours of infraction. Appeals must be faxed to: (678) 528-3117.

FASTRAK CONSIDERS CHEATING WITHIN THE BOLTS OR THE INTENT TO CHEAT A VERY SERIOUS OFFENSE AND IN DIRECT CONFLICT WITH CRATE ENGINE RACING AS IT WAS ORIGINALLY INTENDED. ENGINE BUILDERS WILL BE BARRED FOR LIFE, BOND FORECLOSED ON (FASTRAK BUILDERS) PLUS FACE SERIOUS FINES AND OTHER POSSIBLE PENALTIES.

APPEAL PROCESS The following is the ONLY appeal process and none other exist implied or otherwise. Must be appealed “in writing” to FASTRAK Corporate office at (678) 935-7304 within 48 hours of said event. In addition must be given to tech man at “that event”. Should competitor not have written appeal within 48 hours of said event, competitor loses all rights to an appeal and agrees to a “hold harmless” contract.

APPEAL HEARING LOCATION Appeal will be heard in FASTRAK Corporate office. A board of teams, track owners, inspectors will be recognized for the appeal process to be heard. The decision of this appeal is final and not to be challenged legally or otherwise. Competitor agrees to a “hold harmless” contract as stated in “temporary or annual membership(s).

ENGINES Engine and components thereof must remain “as from factory”. Only GM 602 and 604 engines are legal in FASTRAK events. The series may test other engine combinations during any FASTRAK sanctioned event touring or weekly. FASTRAK reserves the right to adjust engine specs/parts in case of reliability issues. NOTE! If you are using a engine with another series seal other than NEW GM BOLTS or FASTRAK SEALS be aware! All parts must be that of GM crate engine you are utilizing from the GM Tech/Spec manual. It is the responsibility of the owner/driver to know if the engine is legal or not. Very few GM crate engine series actually run all GM parts as from factory other than FASTRAK. This includes but is not limited to valve springs, oil pump and parts thereof.

WEIGHTS GM 602 - Car and Driver 2100 GM 604 - Car and Driver 2300
(Minus 25 lbs for Hans or similar device or TRUE containment seat) Containment seats must be approved by tech man to get deduction for weight.

TIRES FT 200/400/600 to get points or to count towards your qualification of WORLD CHAMPIONSHIP EVENT. Other tires may be allowed from time to time based on areas, track tires, area tires, etc. Other tires will not be counted towards events or qualifying for World Championship.

TIRE CHEMICAL ALTERING No tire may be altered chemically at ANY FASTRAK EVENT WEEKLY OR TOURING. Chemically altering tires is dangerous to your health and to the health of the other competitors, officials, fans, etc. Tires may be checked by Officials “without notice”. Tires will be checked by lab for altering. Penalties are as listed.

- 1) 1st offense \$5000 fine, loss of points and money for the event
- 2) 2nd offense \$10,000 fine, loss of points and money for the event
- 3) 3rd offense \$50,000 fine, loss of all points and monies for the event.

Competitor/car/owner may not compete again until fine is paid IN FULL. May also result in legal penalties from EPA. *Lab results are final.*

TIRE PROTEST FEE Tire protest fee is \$150 per tire. *Lab results are final. Must be protested before car leaves scale area. Anyone competing in the event may protest tires.*

FUEL Must claim type of fuel you are running for a “comparison test”. May also do “hydrometer test”. **750 MAXIMUM SPECIFIC GRAVITY** Ethanol will be “water tested”. 85 CONTENT + OR – 5.

1st offense \$2500
2nd Offense \$5000
3rd Offense \$10,000

CARBURETORS Any 750 CFM carb or smaller. Must have 1 11/16ths base plate maximum.

Maximum venturi measurement 1.375
Billet base plate may be used. (.780) MAXIMUM thickness
Carb Spacer 604 - 1" inch maximum (NO TOLERANCE) 602" 2 inch spacer maximum (NO TOLERANCE)
(DO NOT TAKE FOR GRANTED. MEASURE IT YOURSELF AND KNOW THAT YOU KNOW)
Spacer may not protrude down into intake at any point
One gasket per surface .070 maximum
Normal aspirated carburetor only. No fuel injection. No nitrous oxide. No aerosol carbs.
Two throttle springs STRONGLY RECOMMENDED.

FUEL SYSTEMS

Mechanical fuel pump only. No electric fuel pumps of any type.

EVACUATION SYSTEMS

Evacuations systems of any type are not legal. This includes breather system to oil pan hookup.

HEADERS

Tri Y headers are not legal. No merge collectors.

(The expense of custom headers has been noted. Should this continue FASTRAK will enforce a "spec" header).

OIL PUMP

Wet Sump only. No external oil pumps even if "inside" oil system etc. (ONE) remote oil filter permitted. (ONE) oil cooler permitted. (604 anything over 45 lbs is suspect)

DISTRIBUTOR

*NO magnetos. Electronic ignition permitted. MSD type box permitted. NO CRANK TRIGGERS OR DEVICES THAT ALLOW FOR EXTERNAL ADJUSTMENT OF TIMING. Series retains the right to exchange boxes without notice.

ELECTRONIC DEVICES

No electronic devices allowing shock adjustment or car from cockpit. Traction control ILLEGAL. Go Pro and similar cameras are permitted.

EXOTIC MATERIALS

All exotic materials are ILLEGAL. That includes titanium or carbon fiber. Carbon Fiber wheel covers are permitted.

TRANSMISSION

In and out box not permitted. Any transmission "without exotic materials" allowed. Must have forward and reverse gears. Drive shafts should be painted white with car number. This is a safety issue! Drive shaft loop is strongly recommended. Automatic transmission permitted. Air shifters not permitted. Carbon fiber, aluminum and steel drive shafts permitted.

REARENDS

Any standard type quick change. No open type (sprint car) rear ends. 9" Ford or similar not permitted. No titanium parts within rear end including wheel studs.

BRAKES

Must have operational 4 wheel braking system. Carbon fiber or other "non magnetic" rotors not legal. Must be magnetic for inspection purposes. Brake rotors and all parts thereof must be magnetic.

WHEELS

MAXIMUM 14". Steel or aluminum only. Beadlocks permitted. Exotic materials no permitted. Wheel covers have become a safety issue. Must have 3 working fasteners.

Metal wheel covers are not legal.

Plastic wheel covers from Aerotech/Dominator are legal beginning in 2015 (any company wishing to have their wheel covers allowed must contact corporate office).

THIS IS A SAFETY ISSUE FOR FANS AND TEAMS

FIREWALL

Must be approved firewall (approved by Series Official) Edges of firewall should be completely 'sealed' in case of fire. Floor should be reinforced for safety. Sheet metal beside driver should be strongly reinforced or use heavier gauge in this location. Metal brace inside towards drive shaft is recommended for safety purposes.

BODIES

(check diagram in rear of rules) ***All measurements are with driver 'in the car'

Ford, GM, Dodge and Toyota bodies allowed.

All body parts must be same as nose. (Ford, GM, Dodge, Toyota)

Standard Dirt type bodies only.

No wedge bodies.

No lips allowed on sides or nose that may be utilized for spoiler purposes. (Inside or outside)

Front fenders and hood must be level and flat from left side to right side of car and at least as far back as engine plate.

No part of fenders or hood may be below outside body line nor angle inward or outward.

A single strip of plastic material along the bottom of doors permitted.

No part of rear deck may extend past quarter panels.

Center of rear hub to end of quarter panel cannot exceed 50 inches. Measured in a horizontal line.

Must have at least one number on both doors and number on roof.

No part of body may "V in" from outside to middle of car or middle of that part.

No wheel skirts.

37 inches from top of door to ground maximum.

Rear Deck height measured from ground 38 inches maximum with driver in car. (measured in the middle)

78 inches at the top of the doors maximum side to side (width). Checked at firewall and behind driver's seat.

72 inches maximum rear width measured at spoiler.

78 inches maximum rear body width measured 12 inches below spoiler.

Maximum width of body measured at bottom of doors 86 inches. Measured in the center of doors.

ELEPHANT EARS: NO MORE THAN 5" TALL. MEASURED WITH STRAIGHT EDGE DOWN TO HOOD.

All non approved bodies and/or any section(s) of the body will be subject too a weight penalty (minimum of 50 lbs) at the discretion of the technical director

ROOFS

Sheet metal, fiberglass or plastic. Carbon fiber edges permitted.

No odd shaped or partial tilted roofs. Must be parallel to body.

Must have roof supports and posts. Bottom of front post Maximum 12 inches. Post must run in straight line and maximum 4 inches total of both sides. May taper at bottom into post.

No V shape of roof measured from outside to middle.

Roof Length Minimum 44 - Maximum 54

Roof Width Minimum 48 - Maximum 52

Quarters windows must be either, both sealed or both open. (If open, cannot be 'offset and must be the same size').

Sail Panel(s) maximum 43 1/2 inches measured at any point on a horizontal plane.

Sail Panel(s) cannot be offset. Must meet edge of body. Maximum 3 inch arch measured on front side.

Sail Panel(s) must be same as body. Re: Ford, Dodge, Chevy, etc

Sail Panel must 'taper down' at rear corner of roof.

Sail panels cannot be offset from each other.

Sail Panels Maximum of **5/8ths** inch lip at any point for support.

No horizontal supports on Sail Panel

Front and rear of roof must roll, not create a spoiler effect.

The roofs are getting out of hand. We will work to create a "rake" rule in 2014. Measured with angle finder.

INTERIOR

Interior body work may be dropped a maximum of 4 inches below the door. Drop interior must be enclosed at firewall in.

Flat interior must maintain a minimum of 11 inches from roll cage to allow for easy exit in case of emergency

Plastic glare shield permitted at front of cockpit as normal method(4 inch maximum height)

NOSE PIECES

Any extensions must be of flexible material. Maximum width of nose piece and extension is 92 inches

Must be mounted flat to top of fenders. Fenders may not "V" in.

Maximum measured from center of front hub is 54 inches at furthest point.
Nose must be same as body type.

SPOILERS

8 inch spoiler only

Metal or Lexan permitted. Plexiglas is not permitted.

Adjustable spoiler permitted up and down only. Side to side not permitted. Spoiler may not be adjustable during the race.
Maximum measurement is 8 inches tall X 72 inches wide.

2 piece spoiler allowed, but must be bolted together at joint and attached to single blade at that joint.

If bolted together, both pieces must be exact same angle.

Measured total of all material including any turns up or down and including support brace.

Spoiler may not extend over side of car

Spoiler blade may extend up to ¾ inch off of back of car

Maximum 3 blades or supports allowed.

Supports or blades maximum length of 18½ inches where it attaches to the car. Includes middle blade.

Blade must have a minimum of 1 ½ inches clearance between front of blade and sail panel.

Blade at front edge must be a maximum height of 4 inches.

If angle material is used to support rear of spoiler, it must be mounted at least ½ inch below top edge of spoiler

Cars with GM 602 engine **MAY utilize 12" inch 'side blades'. Middle blade 'if used' must remain 8 inches. Both side blades must be the same size.

*12" inch side blades. Taper from 4" front to 12" rear

"Stackable" spoilers are not permitted

ROCKET CARS: ROCKET HAS TWO SPOILERS. MAKE SURE YOU HAVE ROCKETS FASTRAK SPOILER.

ROLL CAGE

No aluminum or titanium cages permitted.

All tubing must be a minimum of 1 1/2 inches and a minimum of .083 wall thickness.

Three bars in driver's side mandatory, two bars in right side mandatory.

Must have a minimum of 1 inch bar, .083 wall thickness in halo section running either front to rear or diagonal across

DRIVERS COMPARTMENT/DRIVER SAFETY

Fire suit mandatory. One or two piece.

Racing shoes and gloves *strongly suggested*

Seat of racing type design and bolted to frame not floor.

Right side head rest mandatory, left side suggested.

Hans, Hutchens, and/or similar safety restraint not mandatory, but *strongly recommended*. (25 lb weight break if used)

Quick release steering wheel mandatory.

Batteries may not be located inside driver's compartment.

Helmet with fire resistant interior. Snell 2005 and up.

Full set of racing seat belts and mounted to frame and not floor mandatory. **NO SEAT BELTS OLDER THAN TWO YEARS! 25 LB WEIGHT PENALTY**

Must have working fire system at all times. Not charged means not working. Gauges must be visible to tech inspector

Mirrors are not allowed

FUEL CELL

Fuel cell must be mounted behind rear end housing between frame rails in what is known as "industry standard".

Must be securely strapped with minimum of two steel straps. (Other state laws may apply, NJ, etc)

Straps must be 2 inches wide x 1/8 inch thick.

Must be mounted inside fuel cell steel box.

No part of fuel cell may be below bottom of rear housing.

SHOCKS:

At this time shocks are open. Should the price become what FASTRAK deems "unreasonable" and an unfair advantage, then a shock rule will be put into effect without notice.

CHASSIS

No part of frame may be aluminum, titanium or other 'exotic' material.

All frames must be a minimum of 2 inches square or rectangular with minimum of .083 wall thickness.

Round tube frames must be a minimum of 1 3/4 inches and a minimum wall thickness of .083. 4130 chrome moly only.

Wheelbase minimum of 102.0 at any time.

Wheel width from side to side is 88 inches maximum. Measured from outside to outside of rear tires.

Wheel spacers permitted.

All lead must be solid blocks. No lead shot permitted.

All lead MUST BE painted white with car number on it. This is a safety issue!

All lead must be securely fastened with minimum of grade 5 bolts minimum of 3/8 inch.

All bolts must be doubled nutted or safety wired. Locking nut alone is not legal.

All "single bolt mount" clamps must have duct tape or pinned at bolt to keep lead from backing off.

25 lbs per bolt mount. One bolt mount 25 pounds, two bolt mount 50 pounds. No one piece over 50lbs.

Jig chassis allowed.

Clip chassis allowed.

No wings or tunnels of any kind allowed on/under the body or chassis of the car. Rock shields are allowed as long as they do not create a spoiler effect. These may be constructed of aluminum or steel provided that they are attached securely to the chassis and are a **MAXIMUM** of 18 inches in height and 24 inches in length. These Shields are designed to protect oil pans and transmissions only and will be permitted in those locations only.

Engine setback 25 1/2 inches. Measured from center of ball joint to front of engine plate.

RADIOS

Radios ARE NOT legal at any time.

Raceceivers mandatory at touring events. Raceceivers must be in working order at all times.

Should there be an issue with your receiver during an event, pull down and advise race official.

CONDUCT RULES

Any driver or crew member that puts their foot on the race track without the assistance of a Series Official will be disqualified immediately. No points awarded. No starting money. This does not include fire or safety instances.

Any person fighting will be fined \$500. Cannot race again until fine is paid. No points or money for that event.

Unsportsmanlike conduct will not be tolerated on or off track while attending an event.

Any driver that is black flagged and does not adhere to flag will be fined \$500.00. No points awarded. No starting money.

Drivers are responsible for ALL persons within their team

SPIN(S)

FASTRAK runs under the "secondary caution" rule. Definition" if the yellow has already been thrown for an accident or spin and someone comes l afterwards, that's a "secondary caution".

If you spin someone out and is seen as *intentional* by Officials, you will go to the rear the 1st time and be disqualified the 2nd time.

If Series Official sees it as intentionally spinning someone, spun competitor **may** be allowed to go back to position.

Two unassisted spins and you are out for the night. 3 spins if you are involved with other cars.

Pulling hoods /anything that constitutes actual race performance is considered stopping on track & result in going to rear!

Internet bashing or defamation may result in membership being 'revoked' and/or fined \$500.

ANY person "touching" an Official at ANYTIME will be disqualified. Loss of points and monies for that event. \$500 fine.

DECAL PACKAGES Decal packages mandatory. Series will furnish decals and designated positions per diagrams provided in member packets. Series reserves the right to display sponsor decals on front fenders of each competitor's car at a FASTRAK event. FASTRAK reserves the right to 10 'specified positions' on each competitor's car, *members or non members*.

*No decals, no points. Also will not be eligible for contingencies and other monies from sponsors.

Event Partners: Event Partners decals are one time partners for that event only. Please feel free to remove decals after event.

Event Partners: Event Partners decals are one time partners for that event only. Please feel free to remove decals after event.

INDIVIDUAL TRACK RULES

Note that track rules on an individual basis may over ride series rules. This is in relation to mufflers, safety items, etc. such as window nets, gloves, etc. Please check with the individual track before attending an event.

DISCLOSURE STATEMENT

**Disclaimer

PLEASE READ CAREFULLY. YOU ARE ENTERING INTO A LEGAL AGREEMENT BY COMPETING AT A FASTRAK EVENT.

By participating in a FASTRAK event, participant(s) is entering into a legal agreement with FASTRAK Companies International LLC/ DBA FASTRAK Racing Series, to be later referred to as SERIES. In addition person(s) participating is also entering into a 'HOLD HARMLESS' contract with above mentioned companies, officers of said companies, sponsors, employees, officers, stock holders, Regional Directors (in good standing) and weekly sanctioned tracks (in good standing). Participant(s) agrees that racing is a dangerous sport and is hereby forfeiting any and all legal rights against all previously mentioned parties for any reason *whatsoever*. Participant(s) also agrees that SERIES may confiscate all parts should competitor be found "illegal". Driver and car owner AGREE that by participating in a FASTRAK weekly or touring event, should competitor be found *illegal*, all rules and penalties stated within FASTRAK RULE BOOK and *penalty* section of FASTRAK RULE BOOK TAKE FULL PRECEDENCE OVER ANY UNDERSTANDING 'IMPLIED OR OTHERWISE'. SERIES reserves the right to "decline" any membership. Series MAY ALSO CANCEL ANY MEMBERSHIP without notice. Participant and parties with said participant(s), understands they are "willingly" agreeing to all terms of this contract and hereby forfeit any and all legal rights of any type INCLUDING BUT NOT LIMITED TO "DEFAMATION OF CHARACTER". Participating in an event constitutes a contract.

FASTRAK cannot be held responsible for accidents.

Welcome to the worlds "largest point fund in crate late model dirt racing". THANK YOU!

Copyright 2010 FASTRAK Companies International LLC

604 Spoiler/Side Blades

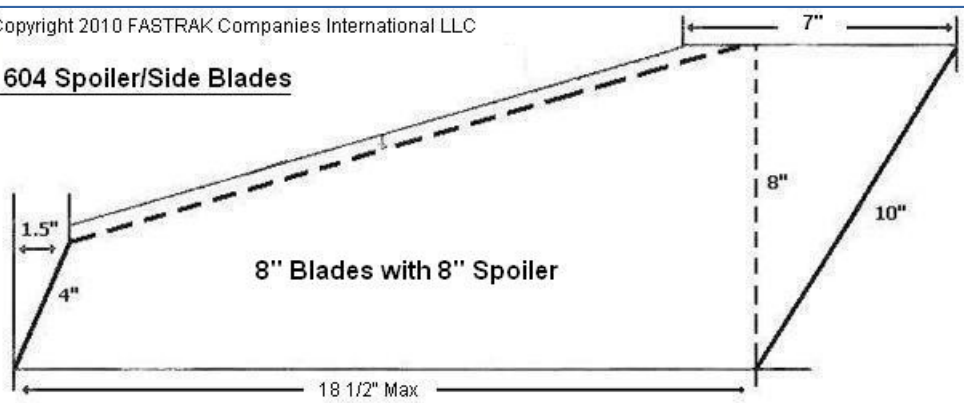

Copyright 2010 FASTRAK Companies International LLC

602 Spoiler /Side Blades

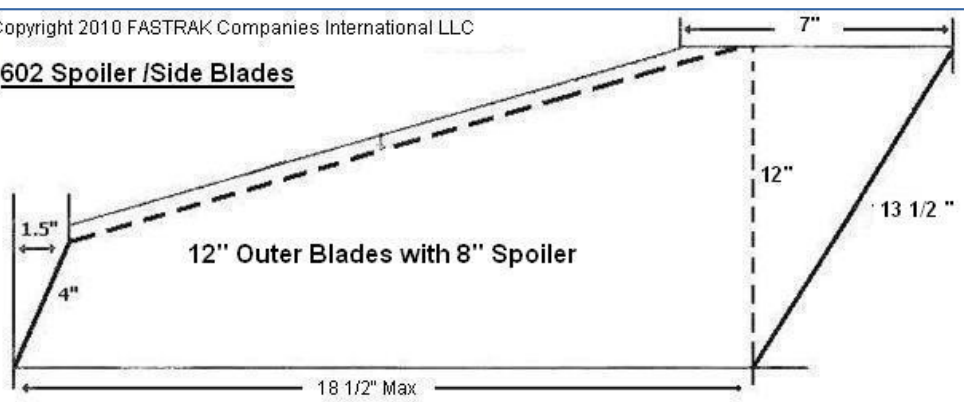

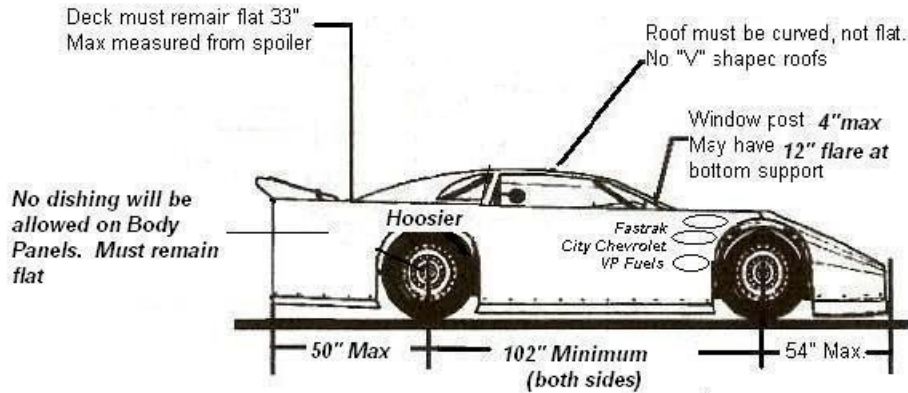

FASTRAK, Hoosier, GM, City Chevrolet, & VP Racing Fuels in specified locations is mandatory

