



The Original Crate Late Model Racing Series

Note from the Founder:

First let me say thank you for choosing FASTRAK as your sanctioning body. It is our honor to have you join us in 2009. 09 brings about some interesting changes that hopefully will help everyone and especially considering the current state of our economy. We, like you have been hit by things that have happened beyond our control so the only thing we could do was try our best to figure out how to cut expenses for you, thereby saving you money. As I always say, "the money I save is the easiest money I ever made".

We have moved money from the Grand Nationals over to the National Weekly Championship in order to take care of more of our weekly competitors. In 08 we awarded the top 30 in the country. In 09 we will award the top 50 in the National Weekly Series. The Grand Nationals will pay \$30,000 to win in 09 versus the \$50,000 to win like it has been in the past paying the top 30 teams coming to Grand Nationals and also having "Bonus Mains" each night for teams not making the "A" Main.

I want to thank our weekly tracks and sponsors and teams that attended the rules meetings at the National Points Banquet this year. It just goes to prove this is still a series whereby the racers actually suggest and vote on the rules for the upcoming season.

Please let us know how we might be of service to you or how we can help. Without our teams, there is no FASTRAK. There are plans of extending to possibly 15 Regions in 09 and increasing the number of weekly tracks to approximately 50. Thanks to you, we are still growing.

My plans are to go to every weekly track in the country in 09. I want to meet each and every one of you and shake your hand. If you see me walking around, stop and tell me who you are. A lot of you I know my name but have never seen in person. Like you, I am just a racer.

Thanks again and God Bless you and your family;

R. Stan Lester
Founder
FASTRAK Racing Series
678-935-7304
sl@fastrakracing.com

BUSINESS NAME AND MAILING ADDRESSES

FASTRAK Racing Series

Corporate Office

PO Box 590

Carnesville, GA 30521

Office: (678) 935-7304

Fax: (706) 384-2546

Founder: R. Stan Lester
President: Mary Kay Combes
Press: Michael Hurley
Weekly Tracks: Don Lester
Points: Michael Hurley
Marketing: Don Lester
Executive Asst: Kelly Norman
Tech Director: Rick Ellison
Regions: Go to www.fastrakracing.com

WEB SITE

www.fastrakracing.com

TECHNICAL UPDATES

Please make sure we have your email address for updates. This is the quickest method we have of getting you 'updated' information. WE DO NOT SEND ANYTHING VIA THE U.S. POST OFFICE.

MEMBERSHIP FEES

2009 membership fees: YOU MUST BE A MEMBER TO RECEIVE POINTS. POINTS ARE NOT 'RETROACTIVE'. YOU WILL NOT RECEIVE POINTS UNTIL MEMBERSHIP HAS BEEN PAID. If membership is paid 'after' event, that event does not count towards points.

National Weekly Championship: \$10,000 to win and pays through 50 positions. \$100 DRIVER FEE. Points start first weekend in April and end the last weekend in September.

Regional Touring Championships: Point fund amounts vary from Region to Region. Contact your regional director. \$100 DRIVER FEE. Points start pertaining to each individual region. Must run 75% of races to receive point money per region.

Grand National Championship: \$30,000 to win and pays through 30 positions for 3 nights of racing at year end. Membership included with either or both, Regional Touring membership or Weekly membership. Must meet minimum race requirements to attend this event. Minimum race events for eligibility may be through either weekly, regional touring or a combination of both. Must be a member of both to receive points for both and/or minimum number of race events for Grand National's eligibility.

YOU MAY BE REQUIRED TO SHOW MEMBERSHIP CARDS AT EVENTS. KEEP THEM WITH YOU AT ALL TIMES.

HOW THE CHAMPIONSHIP AND POINTS SYSTEMS WORK (detailed explanation)

***GOODYEAR/FASTRAK SPEC TIRES MUST BE PURCHASED THROUGH FOSTRAK 'AUTHORIZED' TIRE DEALERS FOR ELIGIBILITY TO COMPETE FOR POINTS. List on www.fastrakracing.com**

NATIONAL WEEKLY RACING SERIES Corporate Office pays the WEEKLY RACING SERIES POINT FUND.

*Must be a member and pay \$100 driver fee.

*Can race at any FOSTRAK weekly sanctioned track in the United States.

*Best 15 finishes. Run as much as you would like.

*If you come to a touring event, it may be counted towards your 'weekly points'.

*If you run at a weekly track that does not use the Goodyear/FASTRAK spec tire as the spec tire for that track, you will only receive 50% of the posted point fund amounts.

Point system:

1)35, 2)34, 3)33, 4)32, 5)31, 6)30, 7)29, 8)28, 9)27, 10)26, 11)25, 12)24, 13)23, 14)22, 15)21, 16)20, 17)19, 18)18, 19)17

20)16, 21)15, 22)14, 23)13, 24)12. 11 points for cars not making the main or having mechanical problems during racing under a "completion green". Does not include practice sessions.

Bonus Points based on car count: Everyone signed in for the event and making an attempt to start. (Must take at least one green flag lap under competition) will receive bonus points. Maximum bonus point 12. Does not include practice sessions.

Example: 5 cars- 5 bonus points to everyone. 10 cars- 10 bonus points, 12 cars – 12 bonus points, 20 cars- 12 bonus points. MAXIMUM BONUS POINTS 12.

Ties will be broken by 1st place finishes then 2nd place finishes and so forth until tie is broken. Ties will be based on ALL finishes not just the best 15. Should tie breaker not be possible, we combine the money amounts and split them equally among those competitors.

REGIONAL TOURING SERIES Each region is responsible for their own Regional Points Fund.

Must be a member of FASTRAK Touring Region to receive points and pay \$100 driver fee.

Points count towards your respective region.

Touring events use the Goodyear/FASTRAK G45/G50 compounds.

Point system is the same as above, 35, 34 and so forth. Points include ALL races in the region you are registered.

No bonus points in Regional Series.

Ties will be determined as above in weekly racing series.

Must run 75% of Touring events in your area to be eligible for Regional point money.

Corporate Office will work on drivers behalf should region not pay point fund.

National events: National events are designated on schedule with purses of \$5000 to win or more. Could be counted towards weekly points and respective regions. (Call your Regional director)

GRAND NATIONALS Grand National Point fund is paid by Corporate Office.

Must be a member of FASTRAK BEFORE races are counted towards minimum race requirements.

Must run a minimum of 12 events (weekly, regional or combination of) to be eligible for Grand Nationals. Must be a member of both Weekly and Touring to count **both** towards eligibility.

Number of races may vary on a region by region basis for unforeseen circumstances. (Such as inclement weather, etc).

Ties in Grand National Points: Point fund amounts will be added together for those positions, then split equally among those competitors.

Everyone starts with 0 points.

Every region holds their own "night 1". (some regions may be combined)

All teams come together and race for nights 2 and 3.

Total of points in the 3 events.

Grand National point checks will be awarded at year ending Regional Banquets

ALL RULES ARE AT THE DISCRETION OF SERIES OFFICIALS AND TRACKS

Series Officials reserve the right to change, delete or amend the rules in the interest of "competition".

Please check FASTRAK weekly sanctioned tracks for rules on an individual basis.

Touring Series runs by Touring Series Rules.

The Series is not responsible for payment of the purse. In the event of any payment problem at a track, the Series will attempt to resolve the problem on behalf of the driver.

ENGINES

GM 602 Car and Driver: 2250 lbs (Touring events allow 1 lb per lap 'burn off' in *feature only*)

GM 604 Car and Driver: 2400 lbs (Touring events allow 1 lb per lap 'burn off' in *feature only*)

All Engines and parts must be as from factory and all components thereof.

Any changes will result in disqualification and no points awarded.

This includes, but is not limited to, harmonic balancers, valve springs, push rods, rocker arms, and after market valve covers.

***NO upgrades are allowed to any engine that may produce power via "performance enhancing methods".

Only FASTRAK "authorized" engine builders have FASTRAK engine seals.

Must be a member of FASTRAK to receive FASTRAK engine seals.

Anyone caught cheating 'within the bolts/seals', will be fined \$1000. The illegal parts will be confiscated and destroyed by the FASTRAK Racing Series and/or tracks or regions of the FASTRAK Racing Series. Competitor

will also be barred for a period of 365 days and will not be allowed to compete at any FASTRAK affiliated track or region. There will be NO changes in this policy 'implied' or otherwise by any FASTRAK affiliate. Competitor will also be barred from Grand Nationals. All teams agree to a 'HOLD HARMLESS' agreement under this policy and

rules within this writing. Drivers will be held responsible for their car and/or cars they may be driving. Competitor will also lose all MONIES and points. This includes all POINT MONIES.

***This rule is also in effect for ALL OPEN SHOWS that are FASTRAK Sanctioned.**

PROTESTS

Top 5 cars can protest anyone within top 5 positions.

Engine CLAIM RULE: GM 602 HP \$3500 Claim GM 604 HP \$5500 Claim
Participant refusing to allow claim will be considered 'illegal within the bolts' and penalties according to such will apply.

Tear Down Rules: All fees must be paid in full within 10 minutes of protested car crossing scales. Protestor must have money in hand for protest. ONCE PROTEST IS DECLARED, IT CANNOT BE WITHDRAWN!

COMPLETE TEAR DOWN: \$800.00 fee. \$200.00 goes to series and/or track (engine will be put back together at FASTRAK "authorized" engine builder for \$600 plus any applicable parts. NOTE: \$600 is for reassembly and re-sealing. Does NOT include any additional needed parts related to wear and tear).

CAM PROFILE: \$300. \$100 goes to Series and/or track.

PULL HEAD AND INTAKE: \$300. \$100 of fee goes to Series and/or track.

WEIGH CRANKSHAFT: \$300. \$100 of fee goes to Series and/or track.

*In the case of two day shows, engines will be marked for legality. Marked engine must be present at post race tech.

*Should competitor change engines, tech personnel must be notified in advance. Both engines may be subject to technical inspection. Engine not inspected in advance will automatically be disqualified.

FASTRAK RESERVES THE RIGHT TO CHECK ANY COMPETITORS ENGINE BY DYNO TESTING, TEAR DOWN, OR ANY OTHER MEANS FOUND NECESSARY TO CONFIRM THE LEGALITY OF AN ENGINE. Any competitor that will not allow testing procedures per the discretion of the Regional Director, Tech Official or FASTRAK Official, will be barred for 365 days and fined \$1000. It is the duty of FASTRAK to keep engines legal per the FASTRAK rule book based on rules of 'fair competition'.

FASTRAK WILL CONTINUE VIGOROUS INVESTIGATION INTO BACKGROUND OF TEAM OWNER, DRIVER, AND ALSO DO INVESTIGATIVE WORK TO FIND ENGINE BUILDER RELATED TO ANY SUCH INCIDENT OF CHEATING. FASTRAK WILL NOT TOLERATE CHEATING WITHIN THE BOLTS/SEALS. FASTRAK WILL PROSECUTE ENGINE BUILDERS FOUND TO BE CHEATING ENGINES OUTSIDE OF GM TECH MANUAL SPECIFICATIONS. LAW PERTAINS TO "SPIRIT OF COMPETITION". DOING ILLEGAL WORK INSIDE OF A SEALED ENGINE IS IN DIRECT CONFLICT OF ANY SERIES UTILIZING SEALED ENGINES. ENGINE BUILDER WILL BE BARRED FOR LIFE, REPORTED TO GM AND EVERY SERIES AND TRACK IN THE UNITED STATES KNOWN TO FASTRAK. ARTICLES WILL BE PUBLISHED IN MAJOR NEWSPRINT SHOULD SUCH INCIDENT TAKE PLACE. We consider this to be a serious offense and it will be treated as such.

APPEAL PROCESS:

Appeals must be made in writing in the following manner

- 1) For weekly tracks: in writing the same night of said protest
- 2) Regional Touring events: in writing the same night of said protest
- 3) In both instances copy of APPEAL must be faxed to FASTRAK corporate office within 48 hours of said protest.

APPEAL will be heard by all parties involved plus someone from the FASTRAK Corporate Office and possibly legal counsel of FASTRAK. By becoming a member of FASTRAK, you are agreeing that the decision made by the corporate office will be final and party posting APPEAL has no legal rights thereafter.

CARBURETORS

*Any 750 CFM Carb or smaller. Must have 1 11/16th base plate maximum. No exceptions.(measured with no go)

*Billet base plates may be used (.780 maximum)

604 1 Inch carb spacer maximum **(0 TOLERANCE)**

602 2 Inch carb spacer maximum **(0 TOLERANCE)**

***Please take time to check your plate** with a gauge, not a tape measure.

Spacer may not protrude into carb or intake at any point. .

One gasket per surface. .070 maximum.

*No fuel injection, nitrous oxide or other type systems allowed.

*Two throttle springs strongly recommended!!

*Aerosol carbs are not legal.

FUEL SYSTEMS

Mechanical fuel pump only.

NO electric fuel pump of any type

EVACUATION SYSTEMS

EVACUATION SYSTEMS ARE NOT ALLOWED OF ANY TYPE!. Note: This means any type vacuum system.

HEADERS

Tri Y headers are not legal.

No merge collectors

*Please note it has been brought to our attention the use of custom headers. Should the price of headers become what the series considers 'unreasonable' and an unfair advantage, the series retains the right to use 'spec headers'.

OIL PUMP

Wet sump only.

No external oil pumps. Even if considered "wet":

Remote oil filter and lines permitted. (One) remote oil filter.

Oil cooler allowed. (One)

DISTRIBUTOR

No magnetos.

Electronic ignition allowed.

MSD type box allowed.

Series retains the right to change MSD boxes at any time without notice.

No crank triggers or devices inside car that allow adjustment of timing.

ELECTRONIC DEVICES

No electronic devices allowed on any car thereby enhancing adjustment of that car.

Electronic brake "cut off" legal on right front only

No remote control devices allowed on any car during any event.

Lap timers allowed during practice sessions only.

No electronic devices controlling shocks.

Exotic Materials:

ALL exotic materials are illegal. That includes titanium and/or carbon fiber.

Carbon fiber drive shafts are legal.

TRANSMISSION

In and out box is not permitted

Any transmission allowed. Must have working clutch and forward and reverse gear.

Lightweight clutches for manual transmissions allowed.

Drive shafts should be painted white with car number. This is a safety issue!!!

Drive shaft loop is highly recommended. This is a safety issue to you and your fellow competitors.

Automatic transmission allowed.

Air shifters not allowed.

Carbon fiber, aluminum or steel drive shafts permitted.

REAR ENDS

Any Standard Quick Change Rear End

No open type (sprint car) rear ends

Traction control not permitted

9 " Ford rear end or similar type rearend not permitted

No titanium moving parts within rear end

BRAKES

All cars must have operational 4 wheel braking systems

Electric or manual proportioning valve permitted
Carbon fiber, titanium or other exotic materials are not legal

WHEELS

Up to 14 inch wheels permitted

Steel or aluminum only
Bead locks permitted
Carbon fiber or titanium wheels are not legal.

TIRES

Tires must be purchased through an “authorized” FASTRAK tire dealer to be eligible for points.

Touring Series: Goodyear G50, G45.

No grooving or siping

Goodyear G70 optional at some tracks. **Right Rear Only.** (For safety purposes on harder tracks). Announced in advance.

Weekly sanctioned tracks reserve the right to run ‘their’ tire rule for weekly sanctioned events.

Tires may be checked by officials at any time. Must meet minimum durometer requirements.

Tires may be marked at discretion of Series. Re: paint marks or other means of identification.

Tires may be confiscated by Series at anytime (for checking numbers versus spec and also for other conditions). Tires will be returned to competitor if found legal.

Tires may be checked by independent lab.

Competitor may be required to break down tire at post race tech for inspection.

Tires will be checked by various methods for treating.

Making the tires ‘softer’ by any means is ILLEGAL.

NO SIPEING. Tire surface must remain as from factory. (smooth)

Once a competitor is found ‘illegal’ they are out for that event in its entirety.

Points will not be awarded.

Any tire by any manufacturer that is found to be a compound other than stamped will be barred from any events now and in the future. Manufacturer will be charged \$50,000.00 fine!

*FASTRAK reserves the right to alter tire rules from the standpoint of “SAFETY AND LOCAL TIRE RULES”

*FASTRAK reserves the right to alter tire rules in the case of supply issues.

FIREWALL

Must be approved firewall (approved by Series Official)

Edges of firewall should be completely ‘sealed’ with silicone or similar material in case of fire.

Floor should be reinforced for safety.

Sheet metal beside driver should be strongly reinforced or use heavier gauge in this location.

BODIES (check diagram in rear of rules)

Ford, GM, Dodge and Toyota bodies allowed.

All body parts must be same as nose. (Ford, GM, Dodge, Toyota)

Standard Dirt type bodies only.

No wedge bodies.

No wings or roof mounted spoilers inside, outside or under car.

No lips allowed on roof, sides or nose that may be utilized for spoiler purposes. (Inside or outside)

All upper and side panels must run parallel to chassis.

Front fenders and hood must be level and flat from left side to right side of car and at least as far back as engine plate.

No part of fenders or hood may be below outside body line nor angle inward or outward.

A single strip of plastic material along the bottom of doors permitted.

No part of rear deck may extend past quarter panels.

Center of rear hub to end of quarter panel cannot exceed 48 inches. Measured in a horizontal line.

Center of hub measured diagonally to top of rear deck maximum 52”

Must have at least one number on both doors and number on roof pointed towards scorers from back straight.

No part of body may “V in” from outside to middle of car or middle of that part.

No wheel skirts.

37 inches from top of door to ground maximum.

Rear Deck height measured from ground 38 inches maximum.

78 inches at the top of the doors maximum. Checked at firewall and behind driver’s seat.

72 inches maximum rear width measured at spoiler.

78 inches maximum rear body width measured 12 inches below spoiler.

Maximum width of body measured at bottom of doors 86 inches. Measured in the center of doors.

ROOFS

Sheet metal, fiberglass or plastic. Carbon fiber edges permitted.

No odd shaped or partial tilted roofs. Must be parallel to body.

Must have roof supports and posts. Bottom of front post Maximum 7 inches. Post must run in straight line and maximum 3 inches. May taper at bottom into post.

No V shape of roof measured from outside to middle.

Quarters windows must be either, both sealed or both open.

Quarter windows maximum 43 inches.

Length Minimum 44 - Maximum 54

Width Minimum 48 - Maximum 52

Front and rear of roof must roll, not create a spoiler effect.

Rear roof supports cannot be offset. Must meet edge of body. Maximum 3 inch arch measured on front side.

Window openings must be same as body. Re: Ford, Dodge, Chevy, etc

NOSE PIECES

Any extensions must be of flexible material. Maximum of 2" outside of front tires.

Must be mounted flat to top of fenders. Fenders may not "V" in.

Maximum measured from center of front hub is 54 inches at furthest point.

Nose must be same as body type.

INTERIOR

Interior body work may be dropped a maximum of 4 inches below the door. Drop interior must be enclosed at firewall in case of fire.

Flat interior must maintain a minimum of 11 inches from roll cage to allow for easy exit in emergencies

SPOILERS

8 inch spoiler only

Metal or Lexan permitted. Plexiglas is not permitted.

Adjustable spoiler permitted up and down only. Side to side not permitted. Spoiler may not be adjustable during the race.

Maximum measurement is 8 inches tall X 72 inches wide.

2 piece spoiler allowed but must be bolted together at joint and attached to single blade at that joint.

If bolted together, both pieces must be exact same angle.

Measured total of all material including any turns including support brace.

Spoiler may not extend over side of car.

3 blades allowed. Rear of blade must be even with rear of deck (tolerance for piano hinge only).

Supports or blades maximum length of 18 inches where it attaches to the car. Includes middle blade.

Blade must have a minimum of 2 ½ inches clearance between front of blade and rear of window post.

Blade at front edge must be a maximum height of 4 inches.

If angle material is used to support rear of spoiler, it must be mounted at least ½ inch below top edge of spoiler

ROLL CAGE

No aluminum or titanium cages permitted.

All tubing must be a minimum of 1 1/2 inches and a minimum of .083 wall thickness.

Three bars in driver's side mandatory, two bars in right side mandatory.

Must have a minimum of 1 inch bar, .083 wall thickness in halo section running either front to rear or diagonal across.

DRIVERS COMPARTMENT/DRIVER SAFETY

Fire suit mandatory. One or two piece.

Racing shoes and gloves mandatory

Seat of racing type design and bolted to frame not floor.

Right side head rest mandatory, left side suggested.

Hans or other type device not mandatory, but *strongly recommended*.

Quick release steering wheel mandatory.

Batteries may not be located inside driver's compartment.

Helmet with fire resistant interior.

Full set of racing seat belts and mounted to frame and not floor mandatory. Oldest date acceptable 2 years prior.

Must have working fire system at all times. Not charged means not working. Gauges must be visible.

Mirrors are not allowed.

FUEL CELL

Fuel cell must be mounted behind rear end housing between frame rails in what is known as "industry standard".

Must be securely strapped with minimum of two steel straps.

Straps must be 2 inches wide x 1/8 inch thick.

Must be mounted inside fuel cell steel box.
No part of fuel cell may be below bottom of rear housing.

FUEL

Methanol and/or alcohol not allowed.
E-85 Ethanol is legal.
Series retains the right to check fuel at anytime.

Propylene, nitro methane, nitro propane or any cancer causing agents are illegal. WILL BE BARRED FOR 365 DAYS.

Grand National Championship (nights 2 and 3)- Sunoco sells the fuel at each event. Fuel will be tested during the Grand Nationals. **If fuel checks wrong, you will be disqualified for entire Grand Nationals.** Loss of all National points and monies from Grand Nationals.

CHASSIS

No part of frame may be aluminum, titanium or other 'exotic' material.
All frames must be a minimum of 2 inches square or rectangular with minimum of .083 wall thickness.
Round tube frames must be a minimum of 1 3/4 inches and a minimum wall thickness of .083. 4130 chrome moly only.
Wheelbase minimum of 103.0 at any time.
Wheel width from side to side is 88 inches maximum. Measured from outside to outside of rear tires.
Wheel spacers permitted.
All lead must be solid blocks. No lead shot permitted.
All lead MUST BE painted white with car number on it. This is a safety issue!
All lead must be securely fastened with minimum of grade 5 bolts minimum of 3/8 inch.
All bolts must be doubled nutted or safety wired. Locking nut alone is not legal.
All "single bolt mount" clamps must have duct tape or pinned at bolt to keep lead from backing off.
25 lbs per bolt mount. One bolt 25 pounds, two bolts 50 pounds. No one piece over 50lbs.
Jig chassis allowed.
Clip chassis allowed.
No underbody shields allowed.
Engine setback 25 1/2 inches. Measured from center of ball joint to front of engine plate.

RADIOS

Radios ARE NOT legal.
Raceceivers mandatory at touring events.
Raceceivers must be in working order at all times.
Should there be an issue with your receiver during an event, pull down and advise race official.
Series will have Raceceivers for sale and rent at all touring events.

CONDUCT RULES

Any driver or crew member that puts their foot on the race track without the assistance of a Series Official will be disqualified immediately. No points awarded. No starting money. This does not include fire or safety instances.
Any person fighting will be fined \$500 for first offense, \$1000 for second offense, and third offense \$5000.
That car will not race again until fine has been paid in full. No points or money awarded for that event.
Unsportsmanlike conduct will not be tolerated on or off track while attending an event.
If you spin someone out and it is seen as intentional by Officials, you will go to the rear the first time and be disqualified the second time.
Any driver that is black flagged and does not adhere to flag will be fined \$500.00. No points awarded. No starting money.
Two unassisted spins and you are out for the night. 3 spins will be allowed if you are involved with other cars.
Pulling hoods or anything that constitutes actual race performance will be considered stopping on the track and result in going to the rear!!!! If Series Official sees it as intentionally spinning someone, spun competitor **may** be allowed to go back to position. Internet bashing or defamation may result in membership being 'revoked'.

DECAL PACKAGES

Decal packages mandatory. Series will furnish decals and designated positions per diagrams provided in member packets. Series reserves the right to display sponsor decals on front fenders of each competitor's car at a FASTRAK event. FASTRAK reserves the right to 10 specified positions on each competitor's car, members or not.
*No decals, no points. Also will not be eligible for contingencies and other monies from sponsors.

Event Partners: Event Partners are one time partners for that event only. Please feel free to remove decals after the event.

INDIVIDUAL TRACK RULES

Note that track rules on an individual basis may over ride series rules. This is in relation to mufflers, safety items, etc. such as window nets, gloves, etc. Please check with the individual track before attending an event.

DISCLOSURE STATEMENT

**Disclaimer

PLEASE READ CAREFULLY. YOU ARE ENTERING INTO A LEGAL AGREEMENT BY COMPETING AT A FASTRAK EVENT.

By signing below or entering a FASTRAK event, participant is entering into a legal agreement with FASTRAK Companies International LLC DBA FASTRAK Racing Series, to be later referred to as SERIES. In addition person signing is also entering into a 'HOLD HARMLESS' contract with above mentioned companies, officers of said companies, sponsors, employees, officers, stock holders, Regional Directors (in good standing) and weekly sanctioned tracks (in good standing). Person signing agrees that racing is a dangerous sport and is hereby forfeiting any and all legal rights against all previously mentioned parties for any reason whatsoever. Person signing also agrees that SERIES may confiscate all parts should person signing be found "illegal". Driver and car owner AGREE that by participating in a FASTRAK weekly or touring event, should competitor be found illegal all rules stated under engine section and penalty section of FASTRAK RULE BOOK TAKE FULL PRECEDENCE OVER ANY UNDERSTANDING IMPLIED OR OTHERWISE. SERIES reserves the right to "decline" any membership. Series MAY ALSO CANCEL ANY MEMBERSHIP IF FOUND CHEATING UNDER ENGINE AND PENALTY SETION OF RULE BOOK. Person signing below understands they are "willingly" agreeing to all terms of this contract and forfeits any and all legal rights of any type INCLUDING BUT NOT LIMITED TO "DEFAMATION OF CHARACTER".

FASTRAK cannot he held responsible for accidents.

FASTRAK Racing Series Body and Spoiler Specification Illustrations

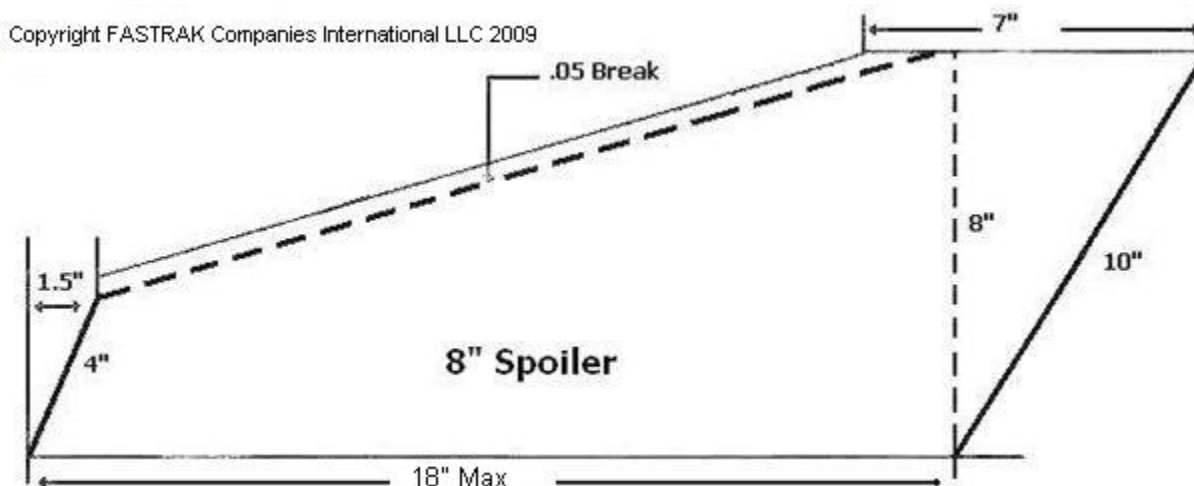

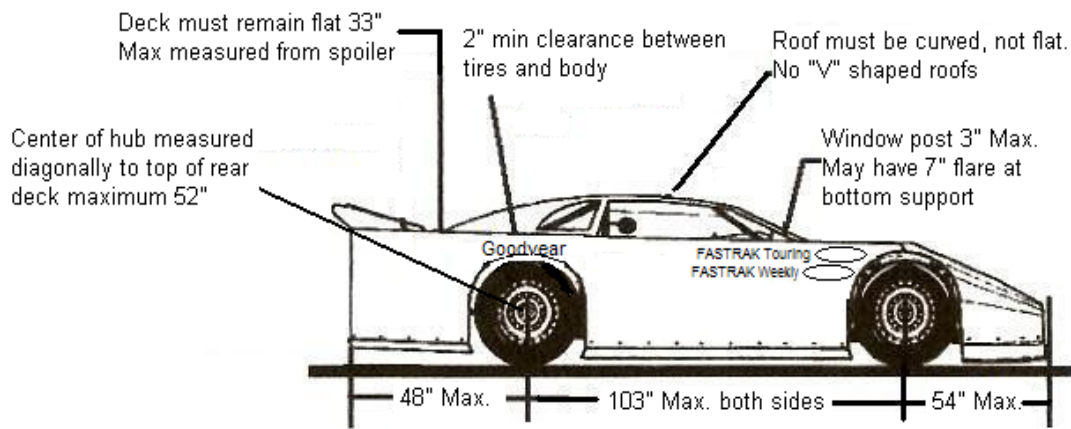

FASTRAK, GOODYEAR and GM Decals in specified locations is MANDATORY

